



Malaguti

IDEE IN MOTO

F 12 LC 2D RETYLING KAT EURO 1



TELAIO - INDICE TAVOLE

FRAME - INDEX OF THE TABLES

TAV.A 	TAV.B 	TAV.C-D 	TAV.E 	TAV.F
TAV.G 	TAV.H 	TAV.I 	TAV.L 	TAV.M
TAV.N 	TAV.OO 	TAV.O 		

MOTORE - INDICE TAVOLE

ENGINE - INDEX OF THE TABLES

TAV.R 	TAV.R1 			
------------------	-------------------	--	--	--

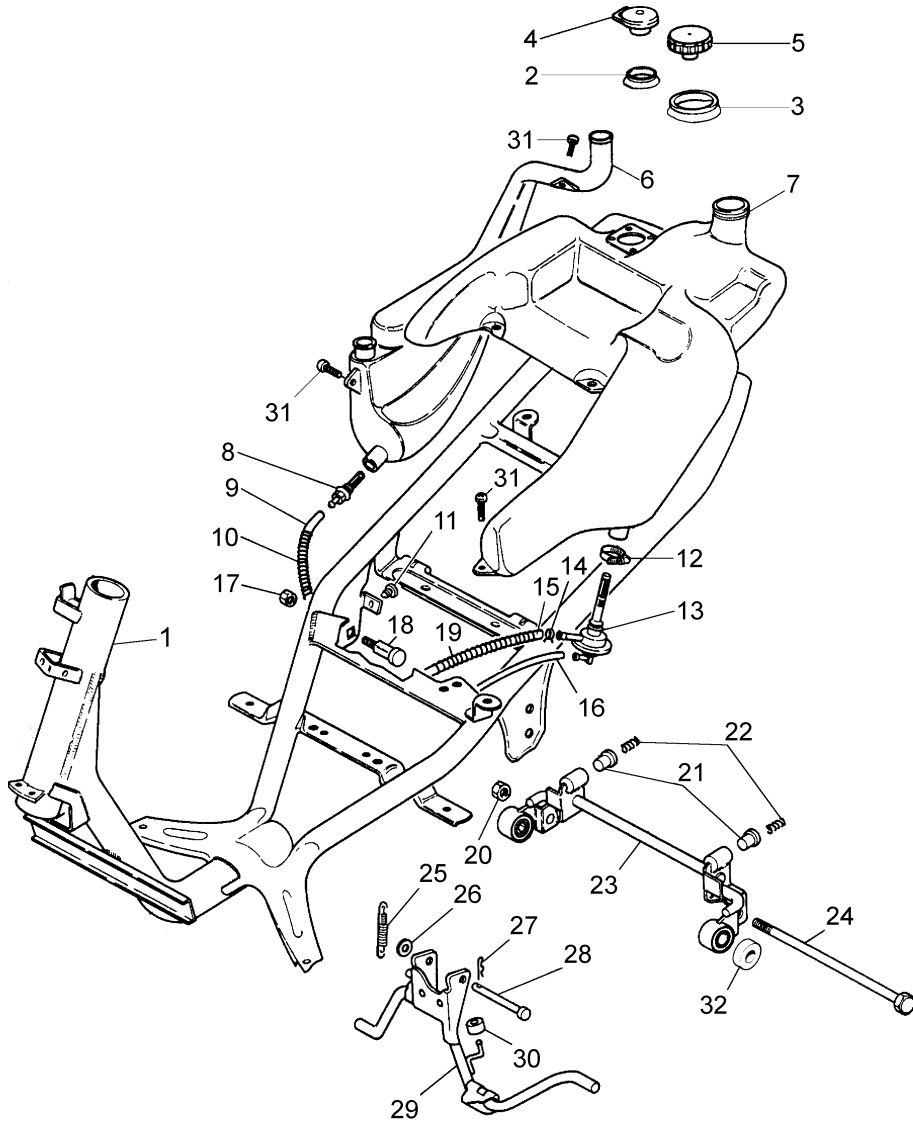

Nr.	Codice	Q.tà	Descrizione
1	156.071.99	1	Telaio
2	071.441.03	1	Coperchio tappo serbatoio olio
3	071.442.03	1	Coperchio tappo serbatoio benzina
4	071.144.00	1	Tappo serbatoio olio
5	092.016.03	1	Tappo serbatoio benzina
6	069.014.00	1	Serbatoio olio
7	161.060.00	1	Serbatoio benzina
8	094.007.00	1	Raccordo olio
9	180.003.54	1	Tubo olio
10	147.102.13	1	Molla tubo olio
11	072.066.03	2	Gommino antivibrante
12	167.031.00	1	Fascetta stringitubo
13	093.045.00	1	Rubinetto benzina
14	167.018.13	6	Fascetta tubo benzina
15	180.010.50	1	Tubo benzina Ø 5
16	180.003.60	1	Tubo benzina Ø 4
17	185.012.00	2	Dado fulcro bilanciere
18	190.020.13	2	Perno supporto motore
19	147.080.13	1	Molla tubo benzina
20	185.011.00	1	Dado fulcro motore
21	080.010.00	2	Portamolla
22	147.106.14	2	Molla antivibrazione
23	174.020.99	1	Attacco motore completo
24	190.019.13	1	Perno motore
25	147.109.13	1	Molla cavalletto doppia

Nr.	Code	Q.ty	Description
1	156.071.99	1	Frame
2	071.441.03	1	Oil tank cap cover
3	071.442.03	1	Fuel tank cap cover
4	071.144.00	1	Oil tank cap
5	092.016.03	1	Fuel tank cap
6	069.014.00	1	Oil tank
7	161.060.00	1	Petrol tank
8	094.007.00	1	Oil pipe connector
9	180.003.54	1	Oil pipe
10	147.102.13	1	Oil pipe spring
11	072.066.03	2	Rubber grommet
12	167.031.00	1	Clamp
13	093.045.00	1	Fuel cock
14	167.018.13	6	Petrol pipe clamp
15	180.010.50	1	Fuel hose Ø 5
16	180.003.60	1	Fuel hose Ø 4
17	185.012.00	2	Engine mount fixing nut
18	190.020.13	2	Engine mount bolt
19	147.080.13	1	Pipe spring
20	185.011.00	1	Lower engine mount nut
21	080.010.00	2	Full bump spring cup
22	147.106.14	2	Full bump spring
23	174.020.99	1	Engine mount bracket
24	190.019.13	1	Lower engine mount bolt
25	147.109.13	1	Main stand spring

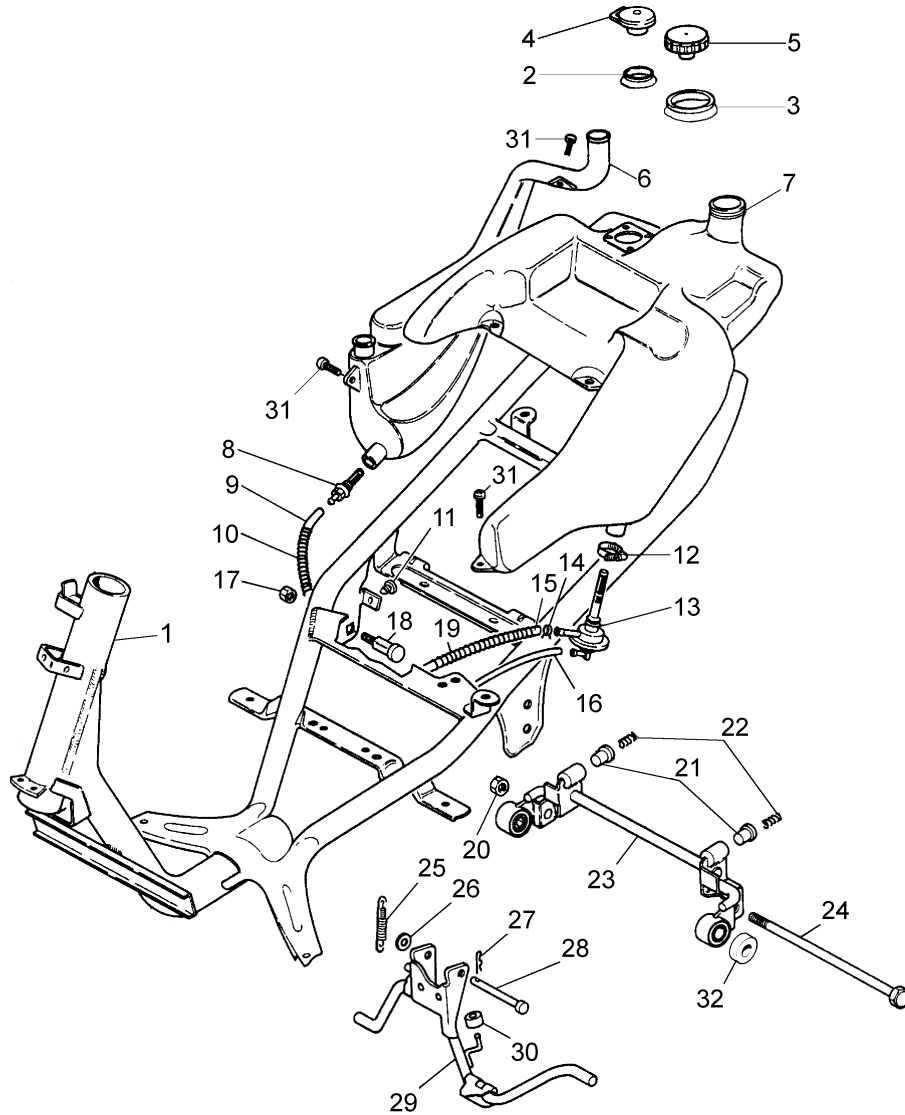

Nr.	Codice	Q.tà	Descrizione
26	071.140.03	1	Rondella in gomma
27	184.011.00	1	Copiglia
28	150.177.15	1	Perno cavalletto
29	158.040.99	1	Cavalletto completo
30	072.064.00	1	Gommino paracolpi cavalletto
31	184.060.15	3	Viti fissaggio serbatoio
32	191.025.13	1	Scodellino
--	090.028.00	1	Kit serrature

Nr.	Code	Q.ty	Description
26	071.140.03	1	Main stand washer
27	184.011.00	1	Split pin
28	150.177.15	1	Main stand pivot pin
29	158.040.99	1	Main stand assy
30	072.064.00	1	Main stand bump stop
31	184.060.15	3	Fuel tank fixing screw
32	191.025.13	1	Cap
--	090.028.00	1	Lock set

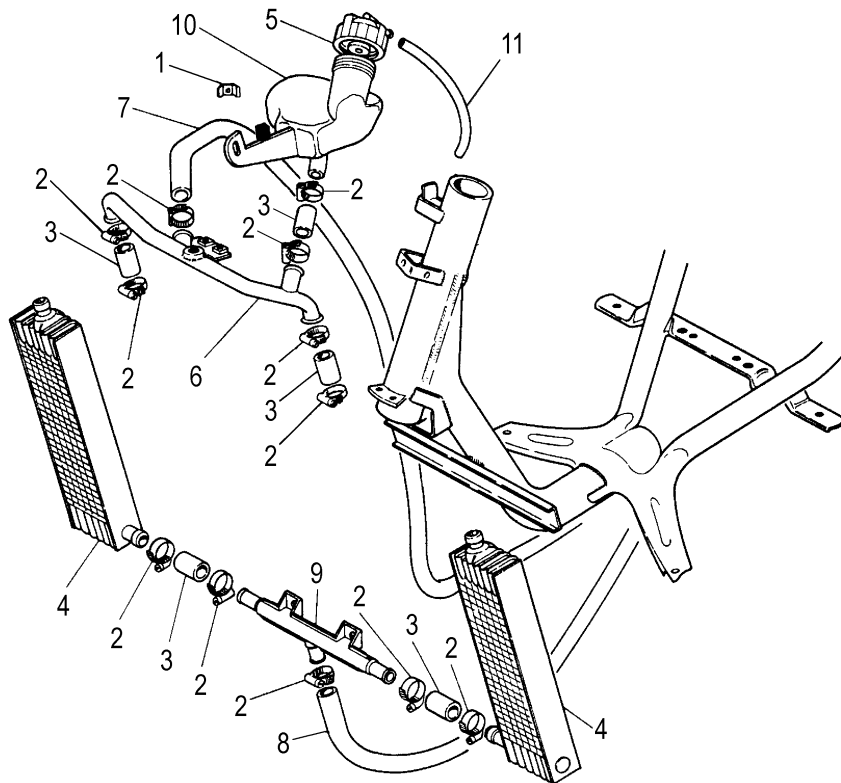

Nr.	Codice	Q.tà	Descrizione
1	191.022.13	1	Piastra attacco vaso espansione
2	167.031.00	12	Fascetta stringitubo
3	077.023.00	5	Manicotto radiatore
4	108.015.00	2	Radiatore
5	071.219.03	1	Tappo vaso espansione
6	077.026.13	1	Tubo mandata raccordo-radiatori
7	077.024.00	1	Tubo mandata motore-raccordo
8	077.029.00	1	Tubo ritorno raccordo-motore
9	077.027.13	1	Tubo ritorno radiatori-raccordo
10	108.016.00	1	Vaso espansione
11	180.002.54	1	Tubo sfiato vaso espansione

Nr.	Code	Q.ty	Description
1	191.022.13	1	Radiator filler neck fix bracket
2	167.031.00	12	Clip
3	077.023.00	5	Water pipe
4	108.015.00	2	Radiator
5	071.219.03	1	Radiator filler cap
6	077.026.13	1	Water delivery pipe
7	077.024.00	1	Water delivery pipe
8	077.029.00	1	Tube
9	077.027.13	1	Tube
10	108.016.00	1	Water tank
11	180.002.54	1	Hose

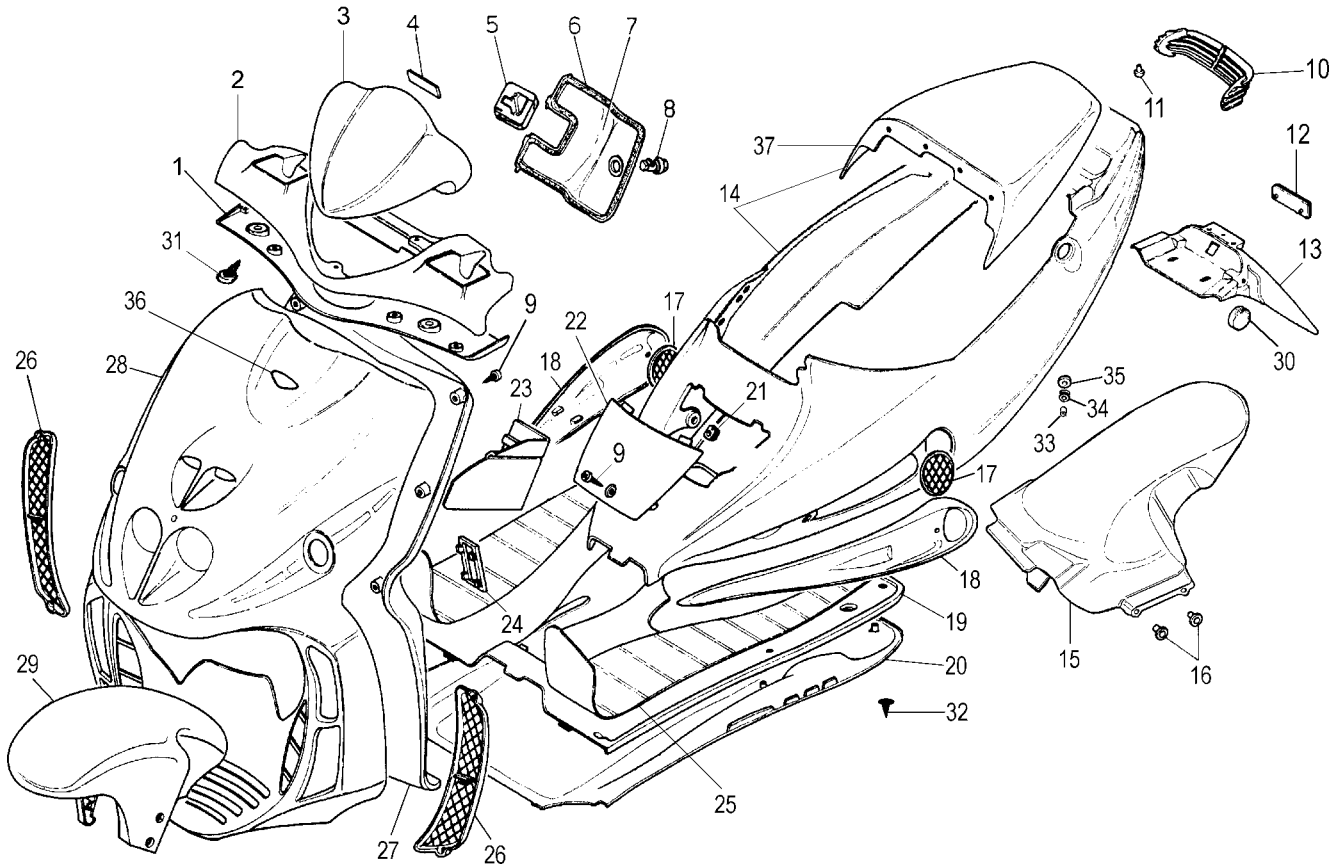

Nr.	Codice	Q.tà	Descrizione
1	071.184.03	1	Coprimanubrio inferiore
2	071.291. - -	1	Coprimanubrio superiore *
3	067.024.03	1	Portastrumenti
4	181.090.00	1	Etichetta in resina
5	071.182.03	1	Gancio borsa
6	072.067.00	1	Guarnizione coperchio batteria
7	071.185.03	1	Coperchio bauletto
8	090.024.00	1	Serratura sportello batteria
9	184.041.15	16	Viti per scudo paragambe
10	071.443.03	1	Griglia fanalino posteriore
11	071.152.03	4	Paracolpi
12	071.322.00	1	Catadiottro
13	057.055.03	1	Codino parafango
14	063.210. - -	1	Carena posteriore con codino *
15	056.058.07	1	Copri ruota posteriore
16	150.148.14	2	Boccola
17	071.192.03	1	Kit griglia carena
18	071.444.03	1	Prese d'aria in coppia
19	064.012.03	1	Pedana in plastica
20	063.102. - -	1	Puntone *
21	184.007.00	14	Clips per viti
22	071.186.03	1	Coperchio carena
23	071.187.03	1	Coperchio batteria

* Vedi tav. N° OO Colori

Nr.	Code	Q.ty	Description
1	071.184.03	1	Handlebar cover (lower)
2	071.291. - -	1	Handlebar cover (upper) *
3	067.024.03	1	Clocks top cover
4	181.090.00	1	Dashboard label
5	071.182.03	1	Bag handle
6	072.067.00	1	Battery cover gasket
7	071.185.03	1	Glove box cover
8	090.024.00	1	Glove box lock
9	184.041.15	16	Fairing screw
10	071.443.03	1	Rear lens grille
11	071.152.03	4	Screw
12	071.322.00	1	Red reflector
13	057.055.03	1	Rear mudguard tail
14	063.210. - -	1	Rear fairing with seat tail *
15	056.058.07	1	Rear mudguard
16	150.148.14	2	Rear hugger fixing bolts
17	071.192.03	1	Grill set
18	071.444.03	1	Air intake grilles
19	064.012.03	1	Foot board panel
20	063.102. - -	1	Belly pan *
21	184.007.00	14	Fairing fixing clips
22	071.186.03	1	Inspection cover
23	071.187.03	1	Battery cover

* Refer to N° OO Colour table

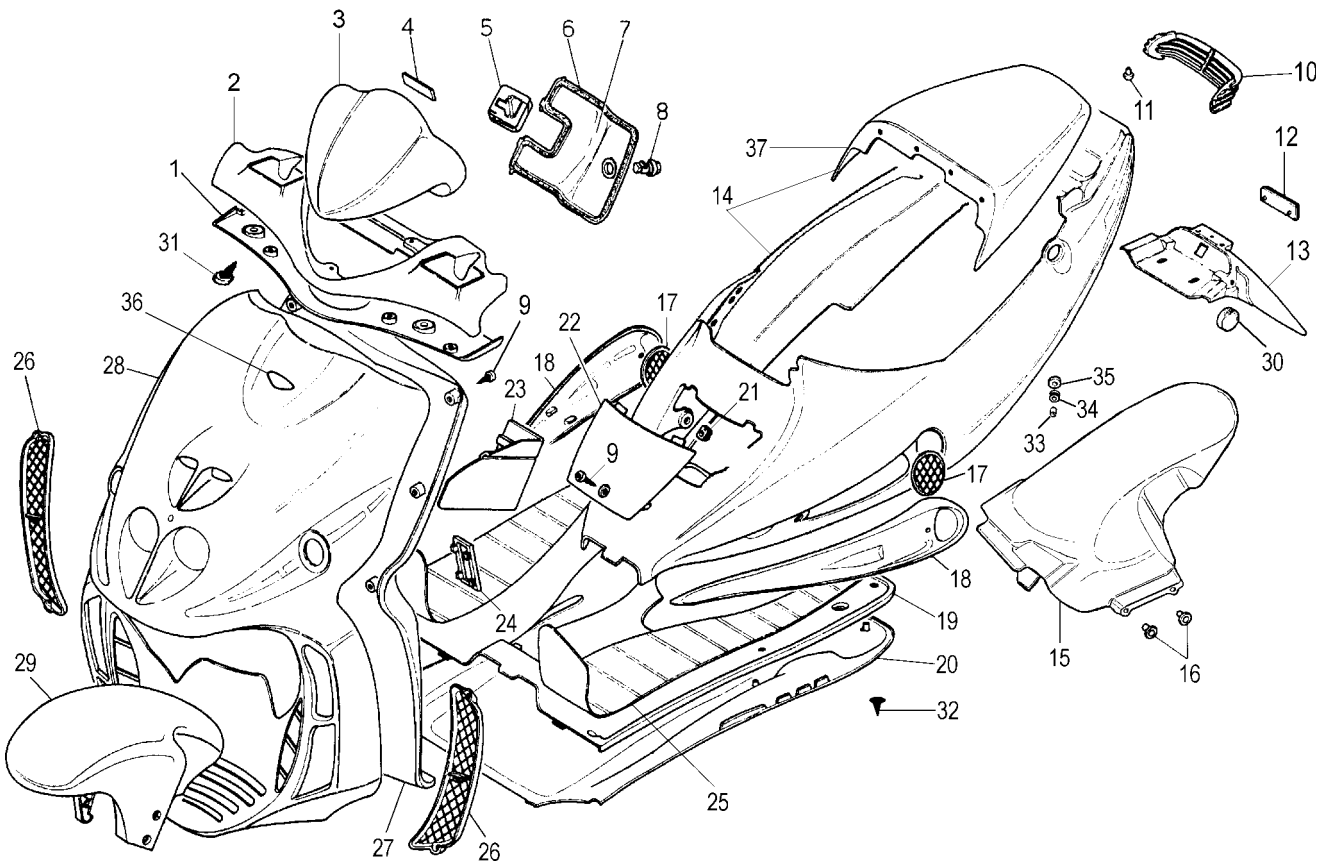

Nr.	Codice	Q.tà	Descrizione
24	071.145.03	1	Coperchio per numeri
25	064.013.07	1	Pedana in gomma in coppia
26	071.192.03	1	Kit griglie scudo
27	065.045.03	1	Paragambe
28	066.085. --	1	Scudo anteriore *
29	055.058. --	1	Parafango anteriore *
30	071.225.00	2	Catadiottro ambra
31	184.071.15	4	Viti autofilettante coprimanubrio
32	184.155.15	6	Vite pedana - carena
33	150.043.00	2	Distanziale
34	080.002.07	2	Gommino
35	072.087.00	4	Rondella speciale
36	181.338. --	1	Marca scudo
37	063.217. --	1	Codino sella *
--	181.303. --	1	Completo marche *
--	181.239.00	1	Completo marche DUCATI
--	181.322.00	1	Completo marche SPECTRUM

Nr.	Code	Q.ty	Description
24	071.145.03	1	VIN numbers inspection cover
25	064.013.07	1	Mat set
26	071.192.03	1	Grille set
27	065.045.03	1	Front inner shield
28	066.085. --	1	Front shield *
29	055.058. --	1	Front mudguard *
30	071.225.00	2	Amber reflector
31	184.071.15	4	Handlebar cover screw
32	184.155.15	6	Footboard bolt
33	150.043.00	2	Spacer
34	080.002.07	2	Grommet
35	072.087.00	4	Washer
36	181.338. --	1	Front shield label
37	063.217. --	1	Seat back *
--	181.303. --	1	PHANTOM label set *
--	181.239.00	1	DUCATI label set
--	181.322.00	1	SPECTRUM label set

* Vedi tav. N° OO Colori

* Refer to N° OO Colour table

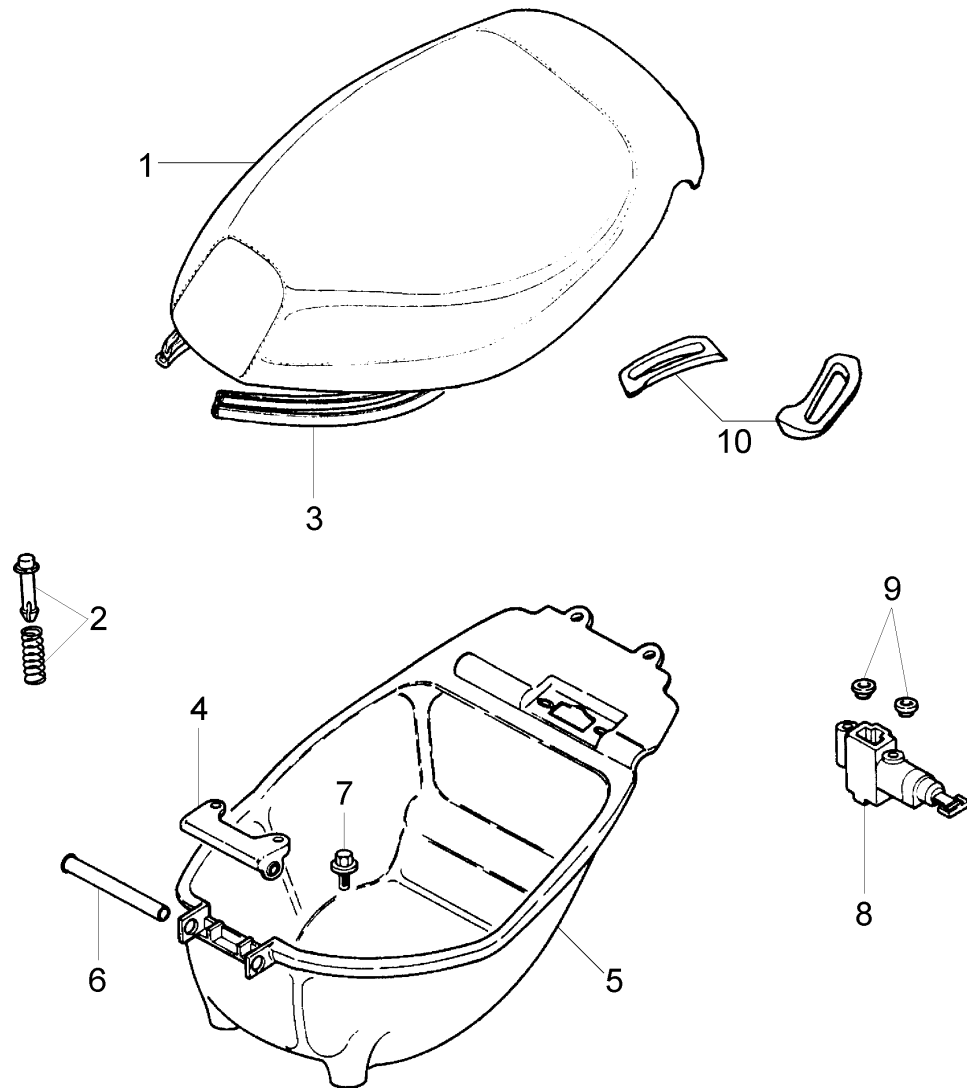

Nr.	Codice	Q.tà	Descrizione
1	106.092.03	1	Sellone
2	071.373.00	1	Push-up apertura sella
3	072.061.03	1	Guarnizione sella
4	188.040.99	1	Supporto sella
5	065.083.03	1	Vano portacasco
6	150.174.13	1	Tubo fulcro sella
7	190.022.00	4	Vite fissaggio vano porta casco
8	090.047.00	1	Serratura sella
9	150.148.14	2	Boccola
10	063.216.03	1	Cp. maniglie sella

Nr.	Code	Q.ty	Description
1	106.092.03	1	Seat
2	071.373.00	1	Seat push-up
3	072.061.03	1	Seat base seal
4	188.040.99	1	Seat hinge bracket
5	065.083.03	1	Helmet case
6	150.174.13	1	Seat hinge pin
7	190.022.00	4	Fixing bolt
8	090.047.00	1	Seat lock
9	150.148.14	2	Fixing bolt
10	063.216.03	1	Handgrip set



Malaguti
IDEE IN MOTO

Scooter F12 LC-2D Restyling KAT EURO 1 TAV. F

Manubrio e comandi - Handlebar & controls

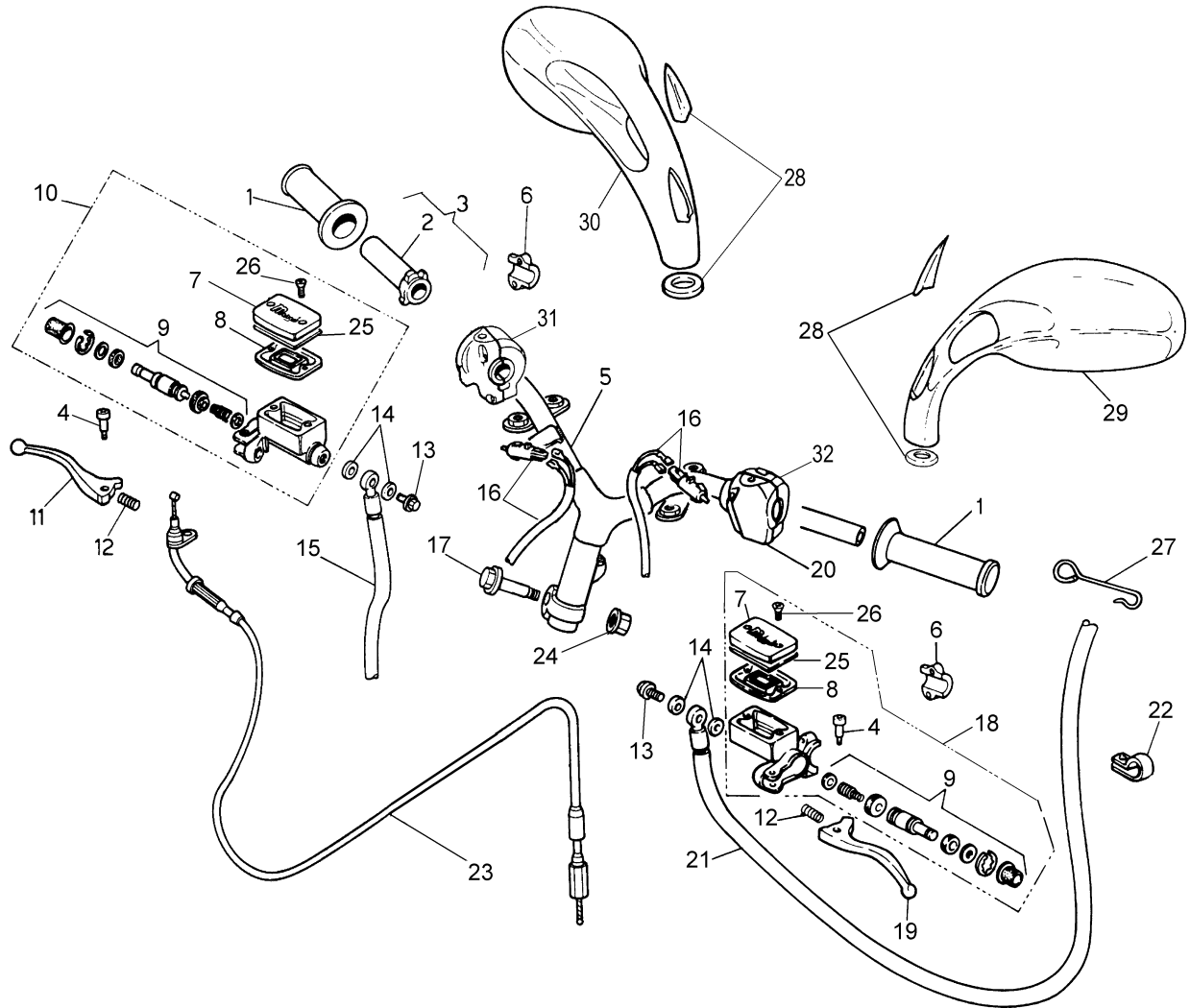

Nr.	Codice	Q.tà	Descrizione
1	097.014.03	1	Kit manopole (dx + sx)
2	121.134.00	1	Tubo comando gas
3	028.018.00	1	Comando gas completo
4	121.106.00	2	Fulcro leva dx
5	162.032.13	1	Manubrio
6	121.139.00	2	Attacco pompa
7	121.127.00	2	Coperchio pompa
8	121.099.00	2	Guarnizione pompa
9	121.128.00	2	Pistone completo
10	030.016.03	1	Pompa freno anteriore
11	121.132.03	1	Leva dx
12	121.108.00	2	Molla leva freno
13	150.024.14	2	Vite trasmissione idraulica
14	190.006.00	4	Rasamento
15	033.035.00	1	Trasmissione idraulica anteriore
16	017.140.00	2	Cablaggio interruttore stop
17	150.179.13	1	Vite fissaggio manubrio
18	030.020.03	1	Pompa freno posteriore
19	121.142.03	1	Leva sx
20	125.031.00	1	Comando sx completo
21	033.033.00	1	Trasmissione idraulica posteriore
22	167.038.00	1	Fascetta trasmissione idraulica
23	034.080.03	1	Trasmissione gas
24	184.056.13	1	Dado fissaggio manubrio

Nr.	Code	Q.ty	Description
1	097.014.03	1	Handgrip set (rh+lh)
2	121.134.00	1	Throttle twist grip tube
3	028.018.00	1	Twist grip tube & bracket
4	121.106.00	2	R/h lever bolt
5	162.032.13	1	Handlebar
6	121.139.00	2	Front brake clamp
7	121.127.00	2	Cover
8	121.099.00	2	Master cylinder seal
9	121.128.00	2	Piston kit
10	030.016.03	1	Master cylinder assy
11	121.132.03	1	R/h brake lever
12	121.108.00	2	R/h brake lever spring
13	150.024.14	2	Banjo bolt
14	190.006.00	4	Copper banjo washer
15	033.035.00	1	Front brake hose
16	017.140.00	2	Brake light switch & wire
17	150.179.13	1	Clamp bolt
18	030.020.03	1	Rear brake pump
19	121.142.03	1	L/h brake lever
20	125.031.00	1	Rear brake control assy (l/h)
21	033.033.00	1	Rear brake hose
22	167.038.00	1	Rear brake hose clamp
23	034.080.03	1	Throttle cable
24	184.056.13	1	Handlebar fixing clamp nut

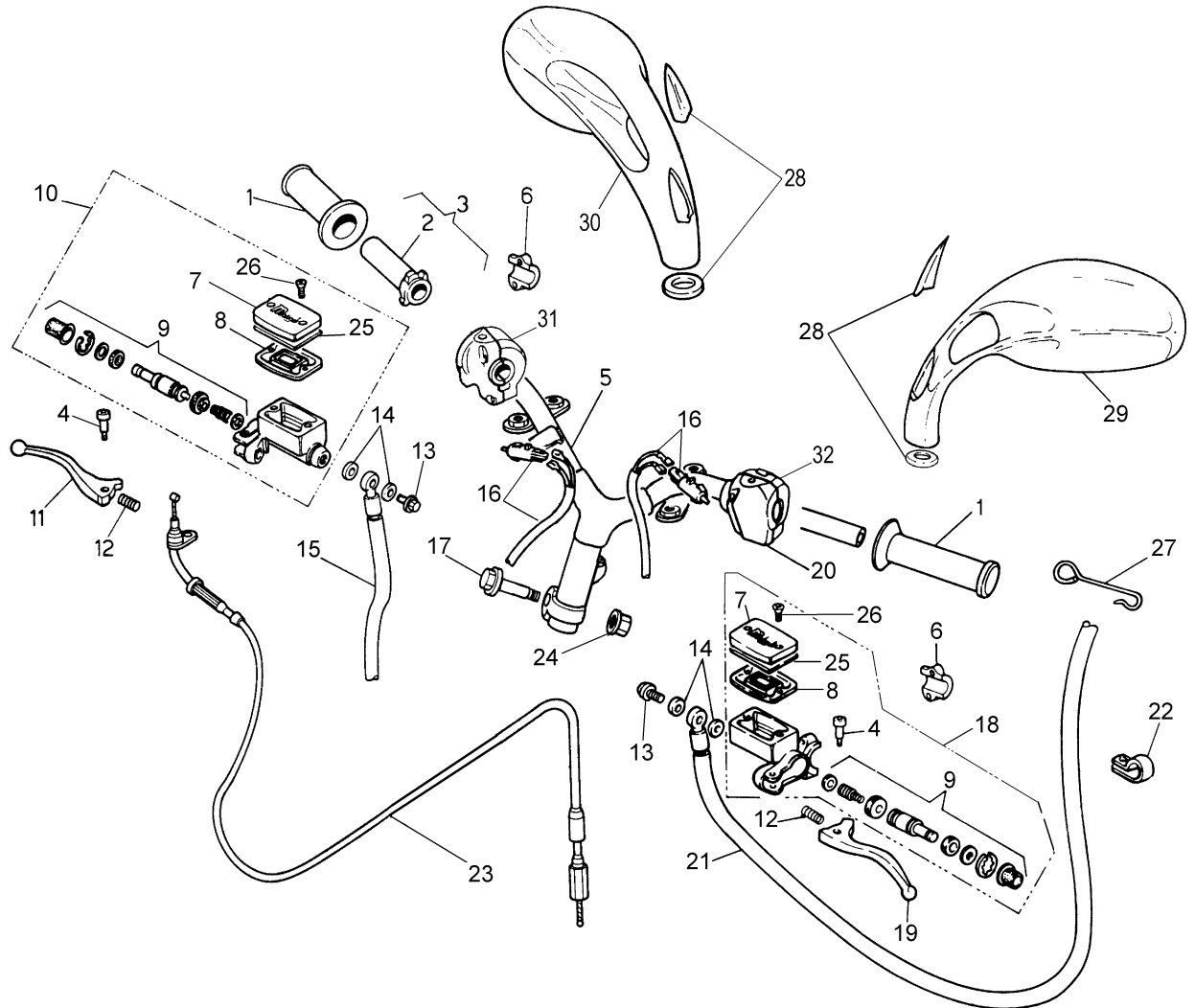

Nr.	Codice	Q.tà	Descrizione
25	121.141.00	2	Scodellino coperchio pompa
26	184.179.00	4	Vite coperchio pompa
27	147.113.13	1	Molla trasmissione idraulica
28	071.254.03	2	Kit tappo specchio
29	088.018. - -	1	Specchio sx *
30	088.019. - -	1	Specchio dx * (di serie mercato estero)
31	020.047.00	1	Commutatore dx
32	020.045.00	1	Commutatore sx con MODE

Nr.	Code	Q.ty	Description
25	121.141.00	2	Master cylinder cover seal
26	184.179.00	4	Brake pump cover screw
27	147.113.13	1	Spring
28	071.254.03	2	Mirror rubber & washer set
29	088.018. - -	1	L/h mirror *
30	088.019. - -	1	R/h mirror * (originally fitted)
31	020.047.00	1	R/h switch
32	020.045.00	1	L/h switch with MODE control

* Vedi Tav. OO Colori

* Refer to N° OO Colour table

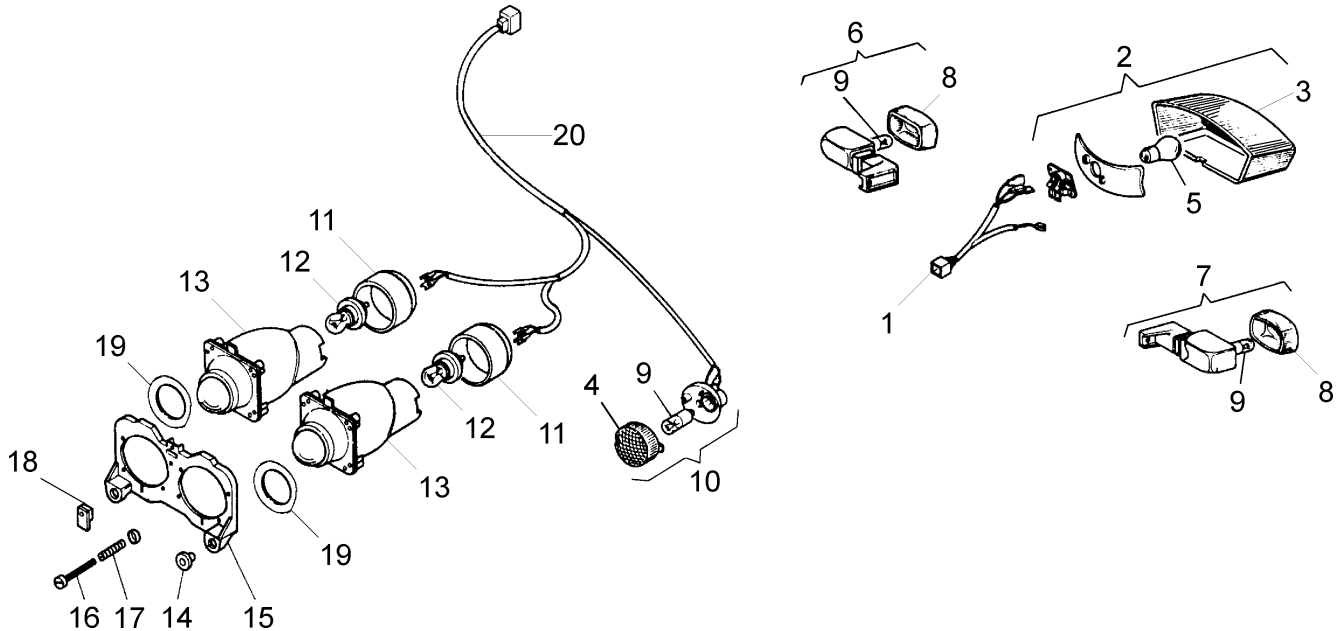

Nr.	Codice	Q.tà	Descrizione
1	017.195.00	1	Cablaggio fanale posteriore
2	016.066.00	1	Fanale posteriore
3	016.069.00	1	Vetro fanale posteriore
4	019.039.00	2	Vetro indicatori anteriore
5	022.048.00	1	Lampadina 12 V - 5-21 W
6	019.075.00	1	Indicatore posteriore dx
7	019.076.00	1	Indicatore posteriore sx
8	019.077.00	2	Vetro indicatori posteriore
9	022.017.00	4	Lampadina 12 V - 10 W
10	019.034.00	2	Indicatori anteriori sx - dx
11	072.069.00	2	Cappuccio faro
12	022.042.00	2	Lampadina 12 V - 15 W
13	015.051.00	2	Faro anteriore
14	075.010.00	2	Gommino supporto faro
15	071.194.03	1	Supporto faro anteriore
16	190.004.00	1	Vite regolazione faro
17	147.038.14	1	Molla regolazione faro
18	191.017.13	1	Piastrina regolazione faro
19	071.445.16	2	Anello adattatore faro anteriore
20	017.248.00	1	Cablaggio faro anteriore

Nr.	Code	Q.ty	Description
1	017.195.00	1	Rear light wiring harness
2	016.066.00	1	Rear light assembly
3	016.069.00	1	Rear light lens
4	019.039.00	2	Front indicators lens
5	022.048.00	1	12 V - 5-21 W bulb
6	019.075.00	1	R/h rear indicator
7	019.076.00	1	L/h rear indicator
8	019.077.00	2	Rear indicators lens
9	022.017.00	4	12 V - 10 W bulb
10	019.034.00	2	L/h+r/h front indicators
11	072.069.00	2	Headlamp rubber cap
12	022.042.00	2	12 V - 15 W bulb
13	015.051.00	2	Head light assy
14	075.010.00	2	Head lamp bracket grommet
15	071.194.03	1	Head lamp bracket
16	190.004.00	1	Head lamp adjusting screw
17	147.038.14	1	Head lamp adjusting spring
18	191.017.13	1	Head lamp adjusting plate
19	071.445.16	2	Head lamp adapter ring
20	017.248.00	1	Head lamp wiring harness

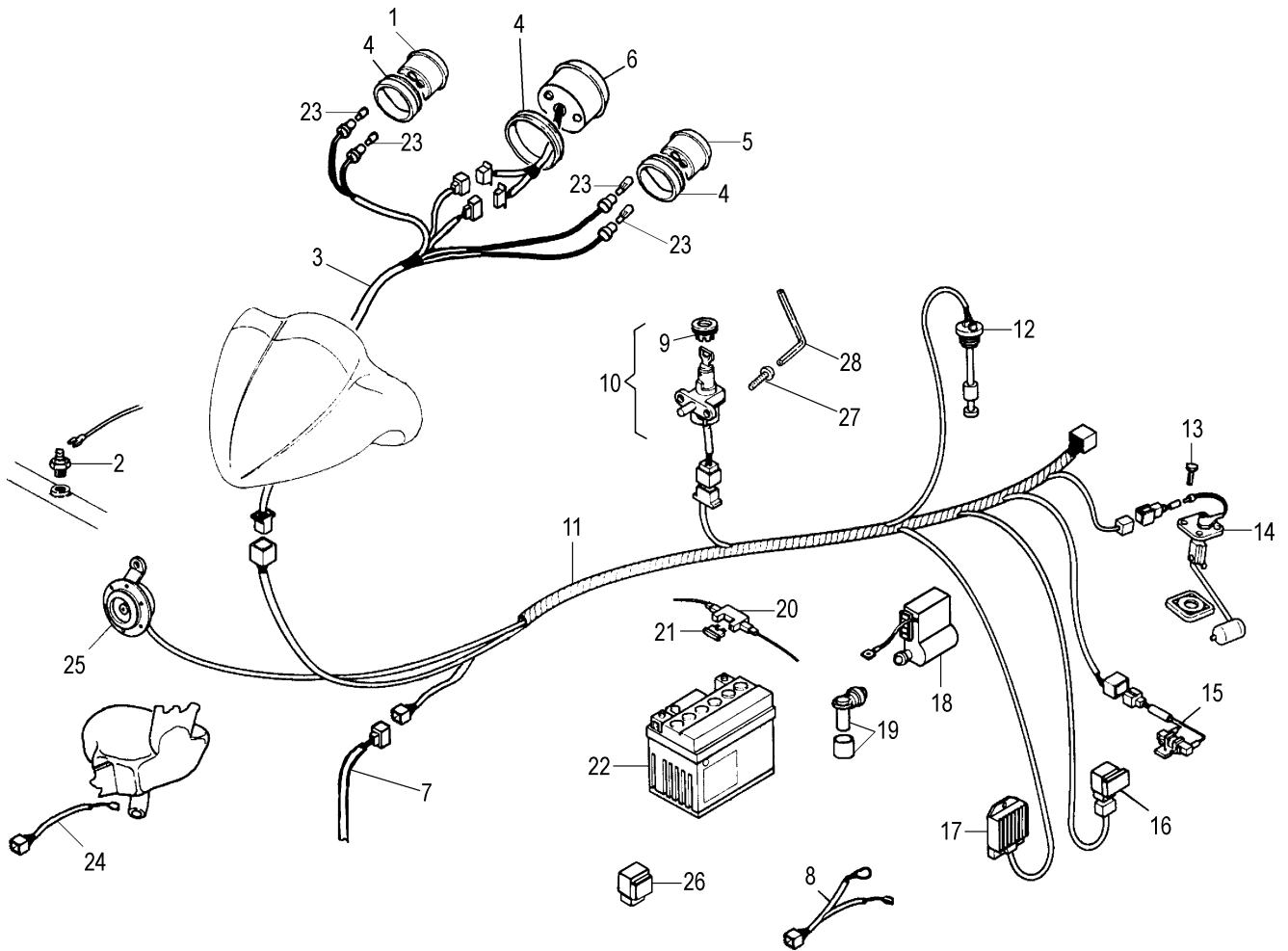

Nr.	Codice	Q.tà	Descrizione
-----	--------	------	-------------

1	178.155.00	1	Orologio spie liquido + luci
2	021.013.00	1	Sonda temperatura acqua
3	017.310.00	1	Cablaggio cruscotto
4	072.059.00	1	Guarnizioni orologi in coppia
5	178.156.00	1	Orologio spie olio + indicatori
6	178.154.00	1	Orologio contakm digit
7	178.129.00	1	Trasmissione contakm digit
8	017.226.00	1	Cablaggio batteria
9	071.163.00	1	Ghiera serratura avviamento
10	090.031.00	1	Serratura avviamento
11	017.312.00	1	Cablaggio centrale
12	093.051.00	1	Sonda livello olio
13	184.009.00	4	Viti fissaggio sonda benzina
14	093.046.00	1	Sonda livello benzina
15	025.014.00	1	Resistenza
16	025.015.00	1	Relais
17	026.011.00	1	Regolatore di tensione
18	024.033.00	1	Centralina elettronica
19	073.007.00	1	Pipetta candela c/cappuccio
20	025.016.00	1	Portafusibile
21	025.010.00	1	Fusibile 10 A
22	074.004.00	1	Batteria 12 V - 4 Ah
23	022.036.00	2	Lampadina 12 V - 1,2 W
24	017.202.00	1	Cablaggio spia livello liquido
25	018.054.00	1	Avvisatore acustico

Nr.	Code	Q.ty	Description
-----	------	------	-------------

1	178.155.00	1	Headlight & coolant indicator
2	021.013.00	1	Water temperature sender
3	017.310.00	1	Dashboard wiring
4	072.059.00	1	Gasket set
5	178.156.00	1	Oil mixer & indicators warning light
6	178.154.00	1	Digit speedometer
7	178.129.00	1	Digit speedocable
8	017.226.00	1	Battery loom
9	071.163.00	1	Ignition lock rim
10	090.031.00	1	Ignition barrel
11	017.312.00	1	Main wiring harness
12	093.051.00	1	Oil level gauge
13	184.009.00	4	Fixing screw
14	093.046.00	1	Fuel level gauge
15	025.014.00	1	Resistor
16	025.015.00	1	Relay
17	026.011.00	1	Regulator
18	024.033.00	1	CDI
19	073.007.00	1	Spark plug cap
20	025.016.00	1	Fuse holder
21	025.010.00	1	10 A fuse
22	074.004.00	1	12 V - 4 Ah battery
23	022.036.00	2	12 V - 1,2 W bulb
24	017.202.00	1	Coolant warning light wiring
25	018.054.00	1	Horn

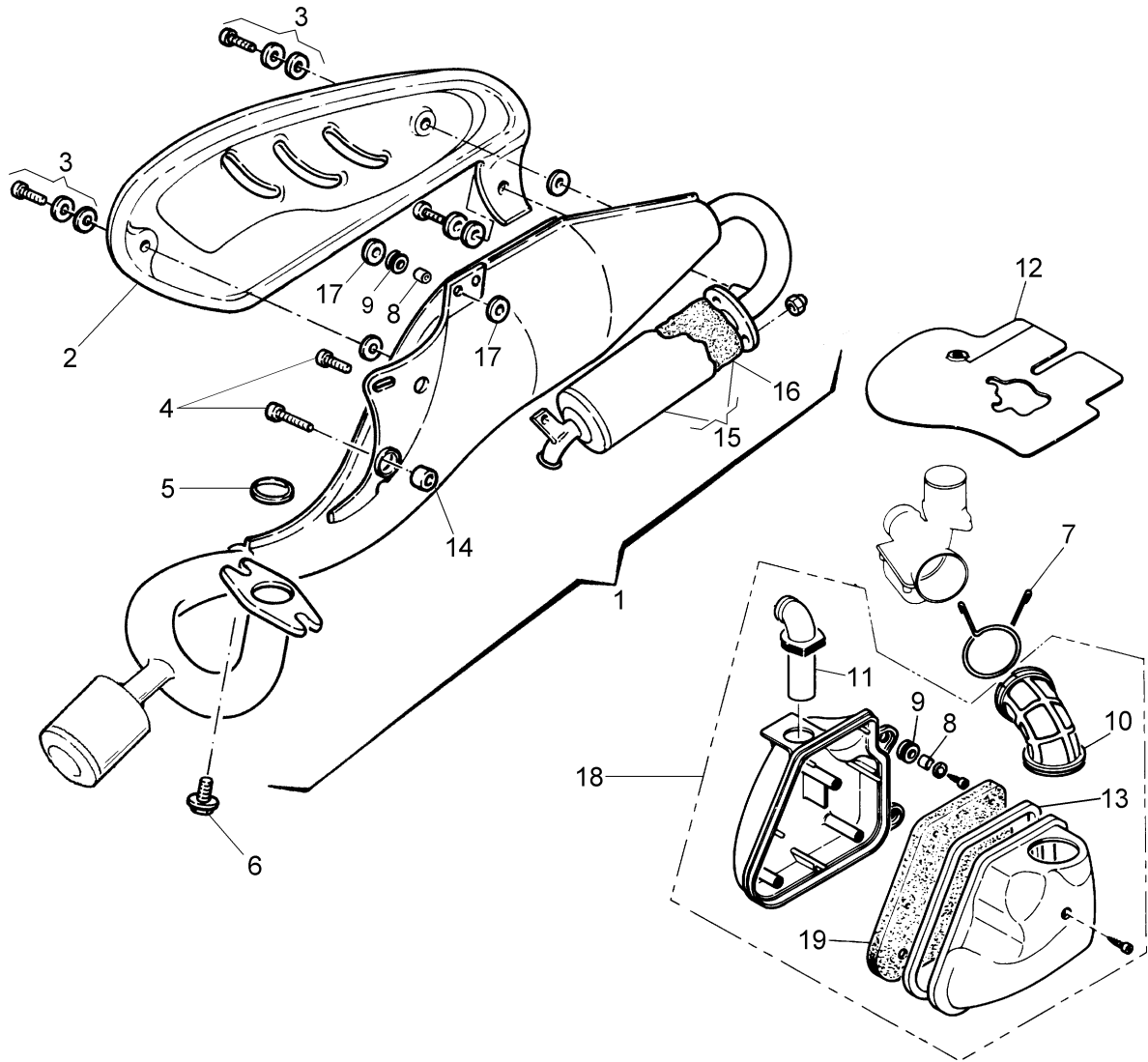

Nr.	Codice	Q.tà	Descrizione
1	165.146.99	1	Marmitta completa catalitica
2	071.341.03	1	Protezione marmitta
3	150.200.00	1	Kit viti fissaggio protezione
4	184.038.13	2	Vite fissaggio marmitta
5	072.053.00	1	Guarnizione scarico
6	184.006.00	2	Vite fissaggio marmitta
7	147.082.13	1	Molla manicotto aspirazione
8	150.043.00	4	Distanziale
9	080.002.07	4	Gommino
10	076.013.00	1	Manicotto aspirazione grande
11	076.012.00	1	Manicotto aspirazione piccolo
12	057.033.00	1	Bancalina carburatore
13	072.056.00	1	Guarnizione
14	075.024.00	1	Silentblock marmitta
15	166.042.08	1	Silenziatore completo kat
16	300.325.00	1	Filtro silenziatore
17	072.087.00	4	Rondella speciale
18	066.058.03	1	Cassetta filtro completa
19	066.045.00	1	Filtro aria

Nr.	Code	Q.ty	Description
1	165.146.99	1	Kat-exhaust assy
2	071.341.03	1	Heat shield
3	150.200.00	1	Fixing screws set
4	184.038.13	2	Exhaust fixing screw
5	072.053.00	1	Exhaust gasket
6	184.006.00	2	Exhaust fixing screw
7	147.082.13	1	Air box hose spring clip
8	150.043.00	4	Spacer
9	080.002.07	4	Grommet
10	076.013.00	1	Air box/carb. sleeve
11	076.012.00	1	Airbox intake sleeve
12	057.033.00	1	Carburettor cover
13	072.056.00	1	Gasket
14	075.024.00	1	Exhaust silentblock
15	166.042.08	1	Kat-silencer assy
16	300.325.00	1	Silencer filter
17	072.087.00	4	Washer
18	066.058.03	1	Air box complete
19	066.045.00	1	Air filter

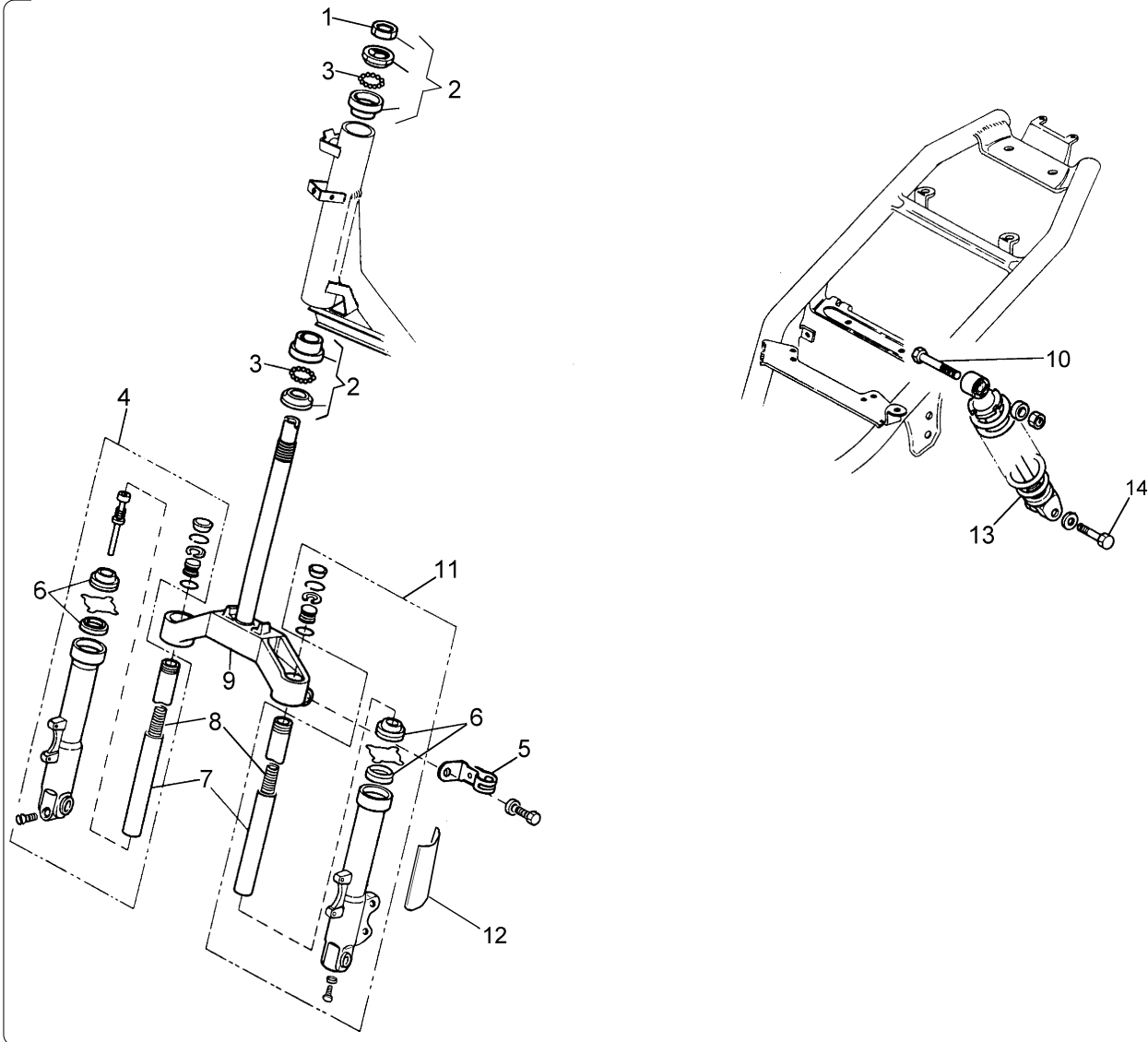

Nr.	Codice	Q.tà	Descrizione
1	185.009.13	1	Ghiera serie sterzo
2	104.017.00	1	Serie sterzo
3	120.261.00	48	Sfere
4	120.317.00	1	Portaruota completo dx
5	147.101.13	2	Molla trasmissione contakm
6	120.312.00	2	Kit parapolvere - paraolio - gommini
7	120.302.00	2	Canna dx + sx
8	120.305.00	2	Molla
9	120.301.99	1	Testa croce
10	184.033.13	1	Vite fissaggio ammortizzatore sup.
11	120.358.00	1	Portaruota completo sx
12	181.123.08	1	Etichetta adesiva foderi dx + sx
13	010.034.08	1	Ammortizzatore
14	184.038.13	1	Vite fissaggio ammortizzatore inf.
--	013.046.50	1	Forcella completa

Nr.	Code	Q.ty	Description
1	185.009.13	1	Steering head nut
2	104.017.00	1	Steering head cap set
3	120.261.00	48	Steering ball cages
4	120.317.00	1	R/h fork leg assy
5	147.101.13	2	Fork leg brake hose clip
6	120.312.00	2	Fork bush/oil seal
7	120.302.00	2	R/h-l/h tube
8	120.305.00	2	R/h-l/h tube spring
9	120.301.99	1	Bottom yoke
10	184.033.13	1	Fixing screw
11	120.358.00	1	L/h fork leg assy
12	181.123.08	1	Tube cover label
13	010.034.08	1	Rear shock absorber
14	184.038.13	1	Fixing screw
--	013.046.50	1	Front fork assy

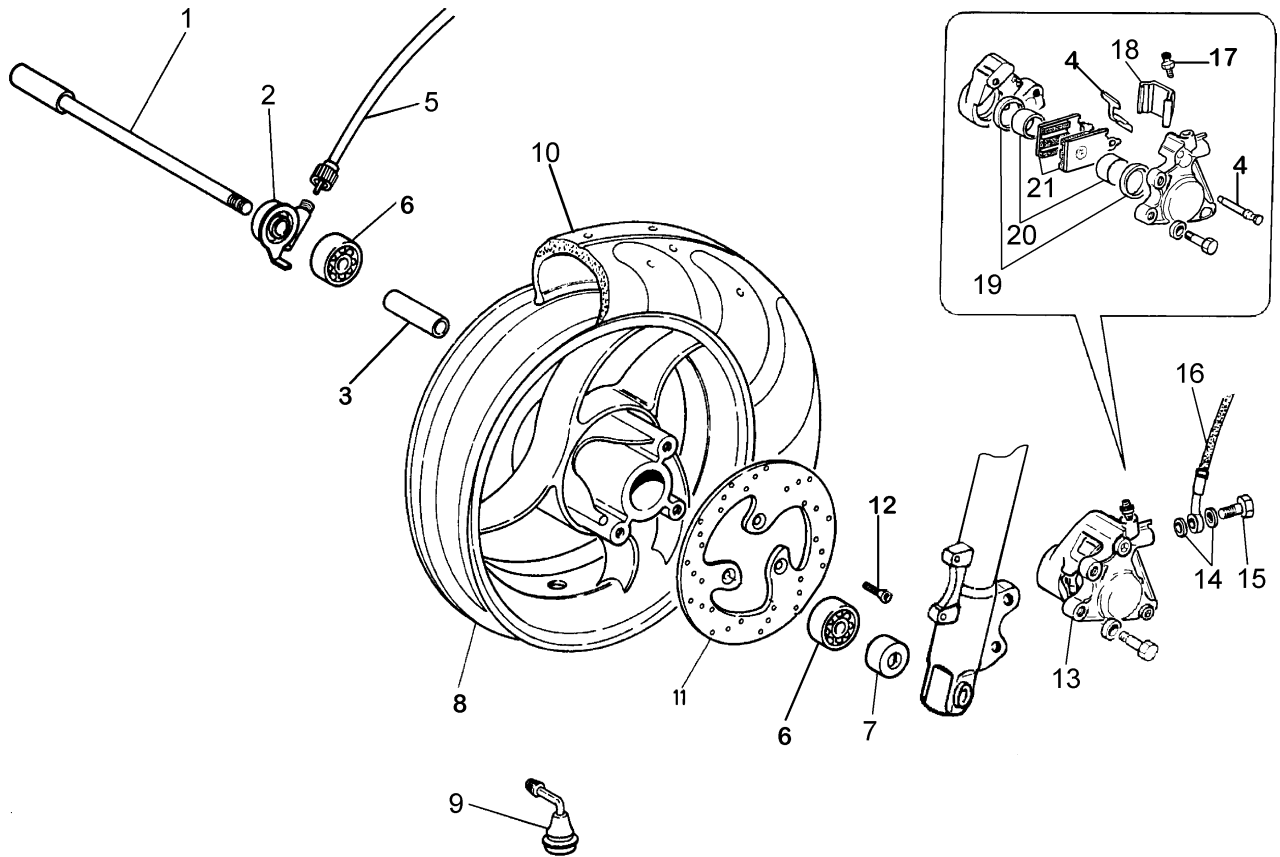
Ruota anteriore e impianto frenante
Front wheel & brake system

Nr.	Codice	Q.tà	Descrizione
1	119.443.00	1	Perno ruota
2	178.126.00	1	Rinvio kontakm digit
3	119.456.00	1	Distanziale interno
4	119.457.00	1	Kit perno + molla
5	178.129.00	1	Trasmissione kontakm digit
6	119.411.00	2	Cuscinetto
7	119.432.00	1	Distanziale
8	109.053. - -	1	Ruota anteriore tubeless *
9	094.008.00	1	Valvola tubeless
10	050.032.00	1	Copertura 120/70 - 12 tubeless
11	119.465.00	1	Disco freno
12	184.287.00	3	Vite fissaggio disco
13	031.019. - -	1	Pinza freno *
14	190.006.00	2	Rasamento
15	150.024.14	1	Vite trasmissione idraulica
16	033.035.00	1	Trasmissione idraulica
17	119.436.00	1	Vite spurgo
18	119.434.00	1	Cuffia
19	119.440.00	1	Serie anelli di tenuta
20	119.435.00	1	Pistone pinza
21	119.502.00	1	Pastiglie freno

* Specificare colore

Nr.	Code	Q.ty	Description
1	119.443.00	1	Front wheel spindle
2	178.126.00	1	Digit speedo drive
3	119.456.00	1	Spacer
4	119.457.00	1	Support pads set
5	178.129.00	1	Digit speedocable
6	119.411.00	2	Bearing
7	119.432.00	1	Spacer
8	109.053. - -	1	Tubeless front wheel *
9	094.008.00	1	Wheel valve
10	050.032.00	1	Tyre 120/70 - 12 tubeless
11	119.465.00	1	Front brake disc
12	184.287.00	3	Brake disc mounting screw
13	031.019. - -	1	Front brake caliper
14	190.006.00	2	Copper banjo washer
15	150.024.14	1	Banjo bolt
16	033.035.00	1	Front brake hose
17	119.436.00	1	Screw
18	119.434.00	1	Brake pad cover
19	119.440.00	1	Seal ring set
20	119.435.00	1	Front brake piston
21	119.502.00	1	Brake pads set

* To be completed with colour code

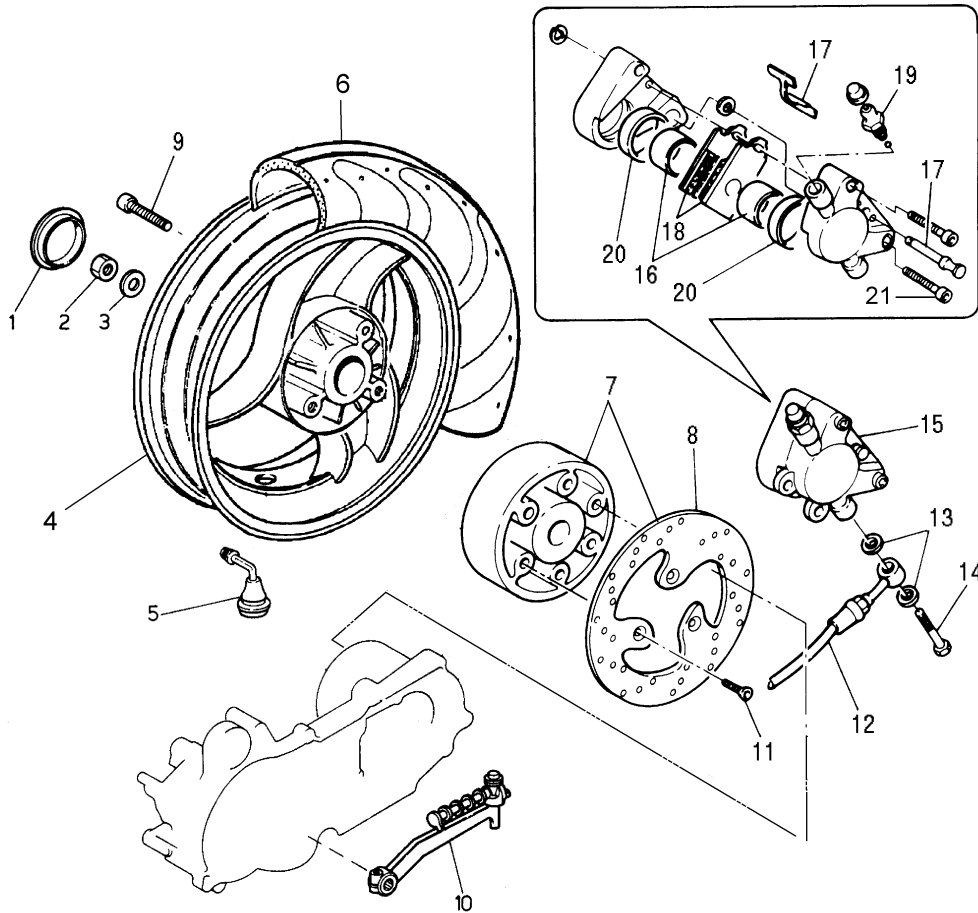
Ruota posteriore e impianto frenante
Rear wheel & brake system

Nr.	Codice	Q.tà	Descrizione
1	071.198.03	1	Tappo ruota
2	185.010.00	1	Dado ruota posteriore
3	119.224.00	1	Rondella
4	110.051. - -	1	Ruota posteriore tubeless *
5	094.008.00	1	Valvola tubeless
6	050.033.00	1	Copertura 130/70 - 12" tubeless
7	114.010.00	1	Mozzo completo di disco freno
8	119.430.00	1	Disco freno
9	184.166.13	3	Vite fissaggio ruota
10	081.009.03	1	Leva messa in moto
11	184.287.00	3	Vite fissaggio disco
12	033.033.00	1	Trasmissione idraulica
13	190.006.00	2	Rasamento
14	150.024.14	1	Vite trasmissione idraulica
15	031.022. - -	1	Pinza freno *
16	119.462.00	1	Kit pistoncini
17	119.459.00	1	Kit perno + molla
18	119.502.00	1	Pastiglie freno
19	119.279.00	1	Vite spurgo
20	119.460.00	1	Kit anelli di tenuta
21	184.248.01	2	Viti unione corpo pinza

Nr.	Code	Q.ty	Description
1	071.198.03	1	Hub cap
2	185.010.00	1	Rear wheel nut
3	119.224.00	1	Washer
4	110.051. - -	1	Tubeless rear wheel assy *
5	094.008.00	1	Wheel valve
6	050.033.00	1	Tyre 130/70 - 12" tubeless
7	114.010.00	1	Rear hub assy
8	119.430.00	1	Disc brake
9	184.166.13	3	Wheel fixing screw
10	081.009.03	1	Kick starter lever
11	184.287.00	3	Disc brake fixing screw
12	033.033.00	1	Brake hose
13	190.006.00	2	Copper banjo washer
14	150.024.14	1	Brake hose screw
15	031.022. - -	1	Rear disc caliper *
16	119.462.00	1	Piston kit
17	119.459.00	1	Bolt & clip set
18	119.502.00	1	Brake pads
19	119.279.00	1	Screw
20	119.460.00	1	Seal ring set
21	184.248.01	2	Screw

* Specificare colore

*To be completed with colour code



TABELLA COLORI - COLOUR CODES

Colori - Colours

N° Nr.	Codice Code	50	53	55	64	70	71	80	87	93	98
		BluNotte-Titanio DarkB.-Titanium	Fast Time Fast Time	Spectrum Spectrum	Blu Acciaio Steel Blue	Giallo Yellow	Ducati Corse Ducati Race	Bianco Perla Pearl White	Argento Lucido Bright Silver	Nero Velvet Velvet Black	Titanio Titanium
1	055.058.	98	93	03	64	70	71	80	87	93	98
2	063.102.	98	55	55	64	70	71	80	87	93	98
3	063.210.	94	53	55	64	70	71	80	87	93	98
4	066.085.	--	53	--	--	--	--	--	--	93	--
5	071.291.	94	93	58	64	70	71	80	87	93	98
6 A	088.018.	94	93	58	64	70	71	80	87	93	98
6 B	088.019.	94	93	58	64	70	71	80	87	93	98
7	063.217.	94	93	55	64	70	71	80	87	93	98
-	181.303.	01	53	--	01	00	--	00	01	01	01
-	181.322.	--	--	00	--	--	--	--	--	--	--
-	181.239.	--	--	--	--	--	71	--	--	--	--

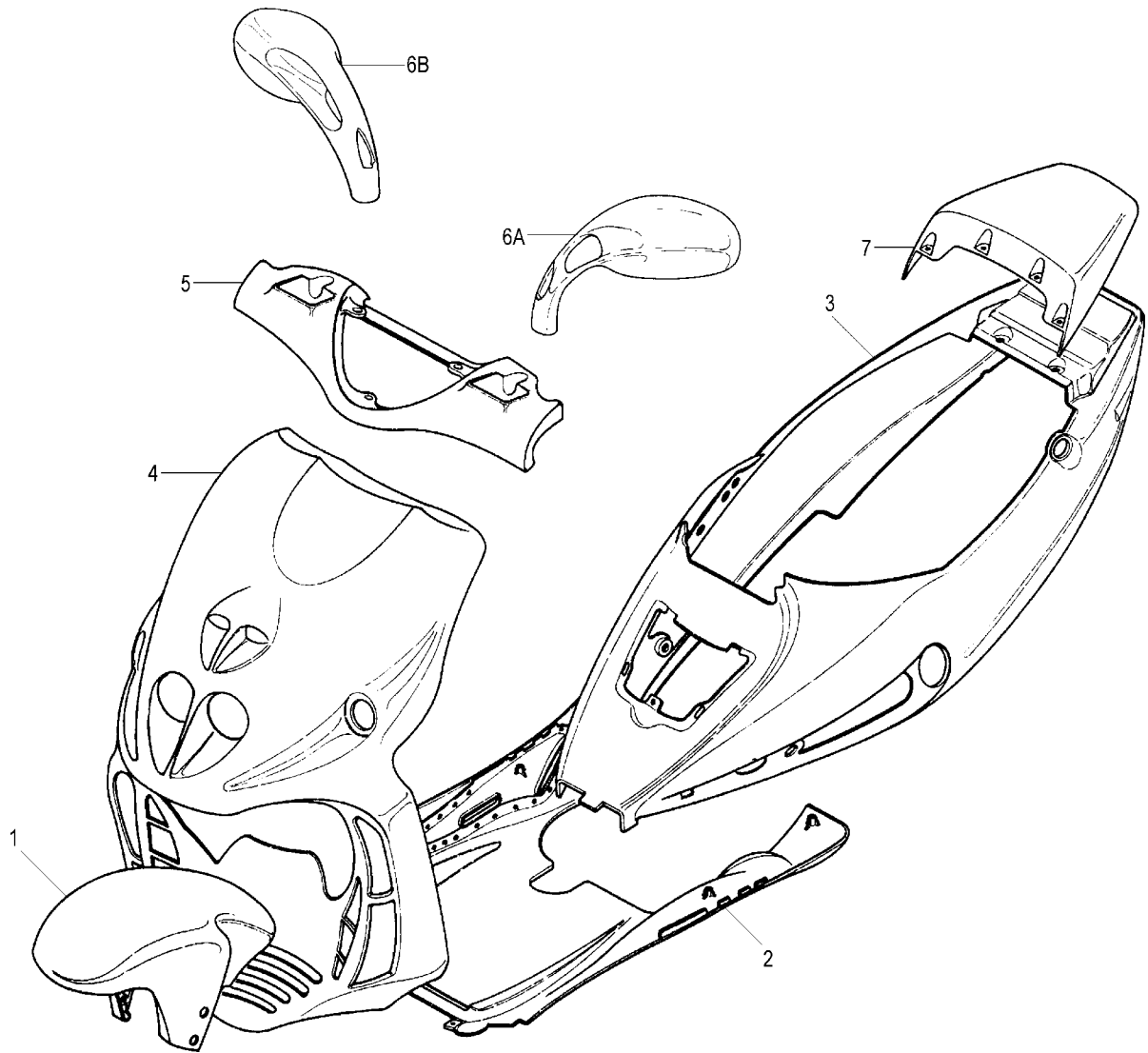
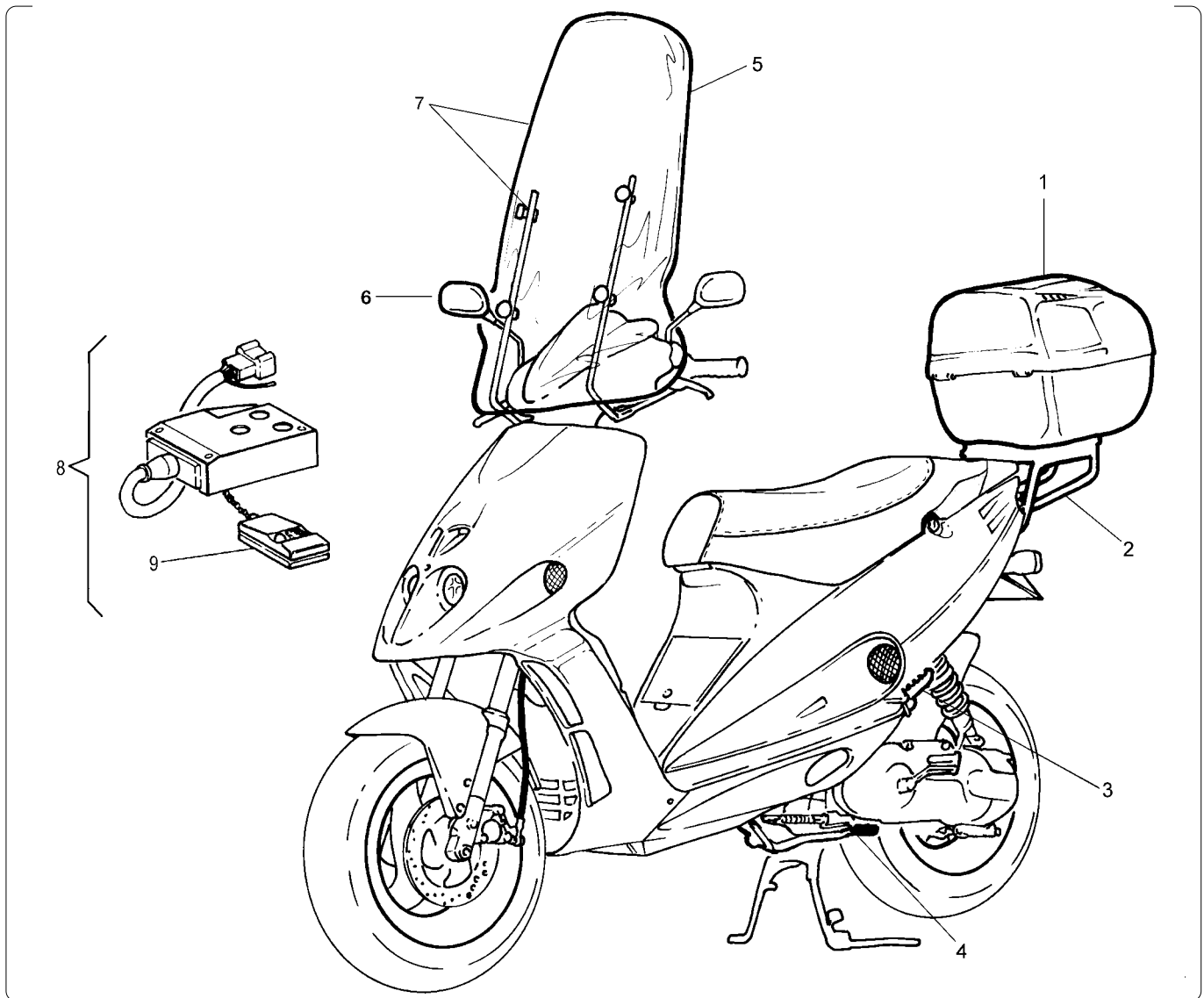

Nr.	Codice	Q.tà	Descrizione
1	065.072.03	1	Baulone porta casco
2	173.048.00	1	Portapacco completo
3	084.033.00	1	Staffe poggiapiedi
4	159.034.99	1	Cavalletto laterale
5	063.145.00	1	Lastra parabrezza
6	088.019. --	1	Specchio dx * (di serie mercato estero)
7	063.108.00	1	Parabrezza completo
8	018.078.00	1	Antifurto elettronico
9	018.079.00	1	Radiocomando
--	065.027.00	1	Coprimoto scooter standard
--	065.077.00	1	Coprimoto scooter con accessori
--	147.112.13	1	Molla cavalletto laterale

Nr.	Code	Q.ty	Description
1	065.072.03	1	Top case
2	173.048.00	1	Rear carrier
3	084.033.00	1	Passenger footrests
4	159.034.99	1	Side stand
5	063.145.00	1	Windscreen glass
6	088.019. --	1	R/h mirror * (originally fitted)
7	063.108.00	1	Windscreen
8	018.078.00	1	Alarm complete
9	018.079.00	1	Remote control
--	065.027.00	1	Scooter canvas cover
--	065.077.00	1	Accessoried scooter canvas cover
--	147.112.13	1	Side stand spring

* Vedi tav. N° OO Colori

* Refer to N° OO Colour table

Nr.	Codice	Q.tà	Descrizione	Nr.	Code	Q.ty	Description
15	715.090.00	1	Carburatore Gurtner PY 12 / R 408	15	715.090.00	1	Carburettor Gurtner PY 12 / R 408
19	771.146.00	1	Cilindro acqua F12	19	771.146.00	1	Cylinder assy
48	024.044.00	1	Motorino avviamento	48	024.044.00	1	Starter motor
62	771.144.00	1	Pistone Ø 40 acqua	62	771.144.00	1	Piston assy Ø 40
77	777.017.00	1	Testa con resche con tappo	77	777.017.00	1	Head assy
82	782.018.00	1	Volano magnete	82	782.018.00	1	Magneto flywheel assy
111	711.008.00	1	Candela con resistore	111	711.008.00	1	Spark plug
172	717.003.00	1	Cinghia di trasmissione	172	717.003.00	1	V- belt
212	721.078.00	1	Coperchio frizione ventilato completo	212	721.078.00	1	Clutch cover
213	721.056.00	1	Coperchio trasmissione	213	721.056.00	1	Gear group cover
214	721.059.00	1	Coperchio lato volano con supporto pompa	214	721.059.00	1	Cover
219	721.060.00	1	Coperchio pompa olio con gommini	219	721.060.00	1	Oil pump cover
381	771.162.00	1	Imbiellaggio	381	771.162.00	1	Crankshaft
382	771.118.00	1	Biella completa	382	771.118.00	1	Connecting rod
601	760.043.00	1	Puleggia anteriore fissa	601	760.043.00	1	Primary fixed pulley
604	760.059.00	1	Puleggia anteriore mobile con boccola	604	760.059.00	1	Primary pulley
606	760.045.00	1	Collettore aspirazione	606	760.045.00	1	Intake manifold
641	764.011.00	1	Pompa olio completa	641	764.011.00	1	Oil pump assy
681	771.142.00	1	Serie segmenti Ø 40	681	771.142.00	1	Piston ring set Ø 40
701	770.022.00	1	Coppia carter	701	770.022.00	1	Crankcase assy
912	701.044.00	1	Albero messa in moto	912	701.044.00	1	Kick start shaft
914	701.051.00	1	Albero uscita moto completo Z=43	914	701.051.00	1	Drive shaft assy Z=43
916	701.058.00	1	Albero trasmissione Z=13	916	701.058.00	1	Gear shaft Z=13
2118	721.077.00	1	Convogliatore uscita aria rosso	2118	721.077.00	1	Air shroud (red)
2119	071.393.03	1	Convogliatore entrata aria nero	2119	071.393.03	1	Cover (black)
2119	071.393.00	1	Convogliatore entrata aria rosso	2119	071.393.00	1	Air intake (red)
2436	724.054.00	2	Gommino chiusura fori carter	2436	724.054.00	2	Rubber cover
2445	724.059.00	3	Gommino ceppi frizione Ø 4x11x5,5	2445	724.059.00	3	Clutch pads grommet Ø 4x11x5,5
2448	724.055.00	3	Gommino perno traino pompa	2448	724.055.00	3	Grommet
2479	724.045.00	1	Gommino silent-block carter	2479	724.045.00	1	Rubber
2485	724.052.00	1	Raccordo plastica sfiato olio	2485	724.052.00	1	Oil breather pipe
2492	724.048.00	1	Tappo alimentazione olio	2492	724.048.00	1	Oil plug
2493	724.049.00	3	Tassello di traino	2493	724.049.00	3	Dowels
2497	724.056.00	1	Tube acqua pompa-cilindro	2497	724.056.00	1	Water pump hose
2601	726.027.00	1	Campana frizione completa	2601	726.027.00	1	Clutch housing
2626	726.028.00	1	Puleggia secondaria fissa completa	2626	726.028.00	1	Secondary fixed pulley
2627	726.030.00	1	Puleggia secondaria mobile completa	2627	726.030.00	1	Secondary pulley
2642	726.045.00	1	Cappello porta tasselli	2642	726.045.00	1	Dowelholder cap
2664	726.021.00	1	Piastrina ritegno paraolio	2664	726.021.00	1	Plate
2665	726.022.00	1	Piastrina ingranaggio doppio intermedio E/S	2665	726.022.00	1	Idle gear plate
2667	726.023.00	1	Piastrina traino puleggia anteriore fissa	2667	726.023.00	1	Drive pulley lock washer
2669	726.044.00	1	Piastra coperchio frizione	2669	726.044.00	1	Cover
2688	726.026.00	1	Scodellino dentato messa in moto	2688	726.026.00	1	Drive plate

Nr.	Codice	Q.tà	Descrizione	Nr.	Code	Q.ty	Description
2689	726.029.00	1	Scodellino porta molla variatore	2689	726.029.00	1	Spring holder
3135	731.009.00	1	Elemento filtrante	3135	731.009.00	1	Filtering part
3520	735.031.00	1	Frizione centrifuga completa	3520	735.031.00	1	Clutch assy
4040	740.142.00	1	Ingranaggio doppio intermedio Z=14/52	4040	740.142.00	1	Idle gear assy Z=14/52
4041	740.121.00	1	Ingranaggio doppio intermedio E/S c/boccola	4041	740.121.00	1	Idle gear assy E/S
4043	740.122.00	1	Corona avviamento elettrico Z=71	4043	740.122.00	1	Kick star sprocket Z=71
4048	740.123.00	1	Ingranaggio conduttore pompa olio	4048	740.123.00	1	Pump drive gear
4066	740.124.00	1	Ingranaggio scorrevole messa in moto	4066	740.124.00	1	Kick start pinion gear
4085	740.125.00	1	Ruota libera completa	4085	740.125.00	1	Free wheel assy
4618	746.048.00	1	Molla puleggia secondaria mobile	4618	746.048.00	1	Secondary pulley spring
4626	746.044.00	1	Molla scorrevole messa in moto	4626	746.044.00	1	Kick start thrust spring
4645	746.051.00	3	Molla richiamo ceppi frizione Ø 1.8	4645	746.051.00	3	Clutch pads spring
4665	746.042.00	1	Molla ritorno leva messa in moto	4665	746.042.00	1	Kick start return spring
4680	746.045.00	1	Molla a disco ingranaggio doppio intermedio	4680	746.045.00	1	Idle gear spring
5104	751.069.00	1	Distanziale Ø 18x23x4.8	5104	751.069.00	1	Spacer Ø 18x23x4.8
5105	751.041.00	1	Boccola albero messa in moto Ø 15x20x30	5105	751.041.00	1	Kick start shaft bush Ø 15x20x30
5108	751.042.00	1	Boccola flangiata corona E/S	5108	751.042.00	1	Bush
5113	751.043.00	1	Gabbia KBK Ø 10x14x12,5 spinotto	5113	751.043.00	1	Cage KBK Ø 10x14x12,5
5127	751.081.00	1	Boccola puleggia anteriore mobile	5127	751.081.00	1	Primary pulley bush
5148	104.028.00	1	Cuscinetto Ø 17x40x12	5148	104.028.00	1	Bearing Ø 17x40x12
5150	751.046.00	1	Cuscinetto Ø 17x40x12 (6203)	5150	751.046.00	1	Bearing Ø 17x40x12 (6203)
5151	751.047.00	2	Cuscinetto Ø 10x30x9	5151	751.047.00	2	Bearing Ø 10x30x9
5179	751.072.00	2	Cuscinetto Ø 17x35x10 (6003/2RS)	5179	751.072.00	2	Bearing Ø 17x35x10 (6003/2RS)
5305	753.135.00	2	Anello di tenuta OR Ø 36x1	5305	753.135.00	2	Oil seal OR Ø 36x1
5315	753.105.00	1	Anello di tenuta OR Ø 13.3x2.4	5315	753.105.00	1	Oil seal OR Ø 13.3x2.4
5320	753.129.00	1	Guarnizione base cilindro	5320	753.129.00	1	Cylinder base gasket
5327	753.120.00	1	Guarnizione coperchio messa in moto	5327	753.120.00	1	Sidecase gasket
5328	753.121.00	1	Guarnizione coperchio trasmissione	5328	753.121.00	1	Gear box gasket
5339	753.109.00	1	Guarnizione statore volano	5339	753.109.00	1	Stator gasket
5347	753.110.00	1	Guarnizione valvola lamelle	5347	753.110.00	1	Reed valve gasket
5359	753.112.00	1	Guarnizione vite scarico olio	5359	753.112.00	1	Oil drain gasket
5384	753.034.00	1	Paraolio Ø 10x18x4 G101840	5384	753.034.00	1	Oil seal Ø 10x18x4 G101840
5602	756.085.00	6	Massa centrifuga foro Ø 9.8	5602	756.085.00	6	Centrifugal roller Ø 9.8
5603	756.078.00	1	Perno pompa acqua con girante	5603	756.078.00	1	Water pump shaft
5612	756.080.00	1	Termostato	5612	756.080.00	1	Thermostat
5615	756.029.00	2	Grano riferimento carter	5615	756.029.00	2	Crankcase locating dowel
5616	756.030.00	4	Grano riferimento coperchi	5616	756.030.00	4	Gearbox locating dowel
5640	756.070.00	2	Perno Ø 8x32	5640	756.070.00	2	Pin Ø 8x32
5653	756.079.00	3	Perno traino girante pompa	5653	756.079.00	3	Water pump drive shaft
5661	756.024.00	1	Rullo ingranaggio condotto pompa RV4	5661	756.024.00	1	Water pump spindle pin
5662	756.071.00	1	Rullo Ø 3x11.8	5662	756.071.00	1	Pin Ø 3x11.8
5668	756.082.00	2	Rullino guida variatore	5668	756.082.00	2	Pin guide
5670	756.073.00	1	Spinotto Ø10x33	5670	756.073.00	1	Pin Ø 10x33

Scooter F 12 LC-2D Restyling KAT EURO 1

Motore 21 MA - 21 MA engine parts

Nr.	Codice	Q.tà	Descrizione
6013	760.048.00	1	Corpo pompa acqua
6015	760.046.00	1	Valvola lamelle completa
9323	703.028.00	2	Anello fermo spinotto Ø 11,8
9351	703.003.00	1	Anello seeger albero
9353	703.005.00	1	Anello seeger albero Ø 15
9360	703.023.00	2	Anello seeger
9368	703.025.00	1	Anello seeger foro Ø 40 spessore 1.75
9375	703.026.00	2	Anello seeger albero Ø 19
9377	703.027.00	3	Anello seeger albero
24100	724.057.00	1	Traino girante pompa acqua
49004	749.148.00	1	Fascetta tubo pompa olio
49005	749.270.00	1	Fascetta antimanomissione flangia aspirazione
49006	167.031.00	2	Fascetta tubo acqua
49015	749.107.00	1	Chiavetta volano magnete
49022	749.223.00	1	Kit tubini unione testa-carburatore
49040	749.210.00	1	Dado M10x1.25
49041	749.181.00	1	Dado M10x1.25 H=8
49055	749.219.00	1	Dado M28x1 (CH=41) H=4
49057	749.183.00	4	Dado M 7x1 fissaggio testa
49058	749.184.00	1	Dado M10x1 H=5.8 (CH=24)
49070	749.186.00	1	Distanziale cuscinetto paraolio frizione
49072	749.212.00	1	Distanziale Ø 21,9x17,5x4,5
49077	749.187.00	1	Distanziale attacco carter
49084	749.188.00	4	Prigioniero fissaggio testa M 7x1x109
49108	749.021.00	3	Rondella grower Ø 6
49129	749.189.00	1	Rondella acciaio blu Ø 15,1x28x1
49148	749.222.00	1	Rondella acciaio Ø 13.2x20x1.3
49162	749.206.00	1	Rondella acciaio blu Ø 14x29x1
49212	184.009.00	2	Vite T.C.B. M5x14 taglio croce
49230	749.088.00	2	Vite T.C.B. M4x10 taglio croce
49232	749.140.00	3	Vite t.c.b. M6x12
49237	749.095.00	2	Vite T.C.C.E. M 5x14
49238	749.065.00	3	Vite T.C.C.E. M 5x20
49243	749.036.00	2	Vite T.C.C.E. M 6x16
49244	749.037.00	9	Vite T.C.C.E. M 6x20
49245	749.068.00	3	Vite T.C.C.E. M 6x25
49247	749.039.00	8	Vite T.C.C.E. M 6x35
49255	749.176.00	3	Vite T.C.C.E. M 6x12
49285	749.191.00	1	Vite T.E M8x1,25x15 scarico olio
49292	184.218.00	3	Vite antimanomissione M6
49338	749.267.00	4	Vite t.c.b. M6x20
49352	749.192.00	1	Rondella conica scodellino
49353	749.193.00	1	Rondella Ø 10.5x18x2

Nr.	Code	Q.ty	Description
6013	760.048.00	1	Water pump housing
6015	760.046.00	1	Reed valve assy
9323	703.028.00	2	Circlip Ø 11,8
9351	703.003.00	1	Kick start circlip
9353	703.005.00	1	Kick start circlip Ø 15
9360	703.023.00	2	Circlip
9368	703.025.00	1	Circlip Ø 40
9375	703.026.00	2	Circlip Ø 19
9377	703.027.00	3	Circlip
24100	724.057.00	1	Water pump shaft
49004	749.148.00	1	Clamp
49005	749.270.00	1	Antitampering clamp
49006	167.031.00	2	Clamp
49015	749.107.00	1	Woodruff key
49022	749.223.00	1	Carburettor heater hose set
49040	749.210.00	1	Nut M10x1.25
49041	749.181.00	1	Nut M10x1.25 H=8
49055	749.219.00	1	Nut M28x1 (CH=41)
49057	749.183.00	4	Nut M7x1
49058	749.184.00	1	Nut M10x1 H=5.8
49070	749.186.00	1	Spacer
49072	749.212.00	1	Spacer Ø 21,9x17,5x4,5
49077	749.187.00	1	Spacer
49084	749.188.00	4	Cylinder head stud
49108	749.021.00	3	Washer Ø 6
49129	749.189.00	1	Washer Ø 15,1x28x1
49148	749.222.00	1	Washer Ø 13.2x20x1.3
49162	749.206.00	1	Washer Ø 14x29x1
49212	184.009.00	2	Screw M5x14
49230	749.088.00	2	Screw M4x10
49232	749.140.00	3	Screw M6x12
49237	749.095.00	2	Screw M5x14
49238	749.065.00	3	Screw M5x20
49243	749.036.00	2	Screw M6x16
49244	749.037.00	9	Screw M6x20
49245	749.068.00	3	Screw M6x25
49247	749.039.00	8	Screw M6x35
49255	749.176.00	3	Screw M6x12
49285	749.191.00	1	Oil drain plug M8x1,25x15
49292	184.218.00	3	Antitampering screw
49338	749.267.00	4	Screw M6x20
49352	749.192.00	1	Washer
49353	749.193.00	1	Washer Ø 10.5x18x2

Scooter F 12 LC-2D Restyling KAT EURO 1

Motore 21 MA - 21 MA engine parts

Nr.	Codice	Q.tà	Descrizione	Nr.	Code	Q.ty	Description
49354	749.194.00	2	Rondella Ø 8x16x2	49354	749.194.00	2	Washer Ø 8x16x2
49501	749.197.00	9	Vite T.C.C.E. M6 x 25	49501	749.197.00	9	Screw M6x25
49502	749.207.00	2	Vite T.C.C.E. M6 x 35	49502	749.207.00	2	Screw M6x35
49503	749.208.00	1	Vite T.C.C.E. M6x45 (nera)	49503	749.208.00	1	Screw M6x45 (black)
49509	749.266.00	2	Vite t.c.c.e. M6x20	49509	749.266.00	2	Screw M6x20
51101	751.066.00	2	Cuscinetto Ø 20x47x14 (83299- 9RTCS31)	51101	751.066.00	2	Bearing Ø 20x47x14 (83299- 9RTCS31)
51107	751.055.00	2	Cuscinetto Ø 8x22x7	51107	751.055.00	2	Bearing Ø 8x22x7
51301	751.053.00	1	Gabbia Ø 57x61x10 (57RFN-6110A)	51301	751.053.00	1	Cage Ø 57x61x10 (57RFN-6110A)
53308	753.128.00	1	Anello di tenuta OR 53,7x1,78	53308	753.128.00	1	Oil seal 53,7x1,78
53309	753.127.00	1	Guarnizione OR Ø 2,62 esterna	53309	753.127.00	1	Gasket Ø 2,62
53310	753.130.00	1	Guarnizione OR Ø 2,62 interna	53310	753.130.00	1	Gasket Ø 2,62
53318	753.160.00	1	Anello di tenuta OR Ø 3x300	53318	753.160.00	1	Oil seal Ø 3x300
53400	753.161.00	1	Guarnizione piastra inferiore	53400	753.161.00	1	Gasket
53501	753.115.00	1	Paraolio Ø 20x30/34x5/6.1	53501	753.115.00	1	Oil seal Ø 20x30/34x5/6.1
53502	753.116.00	1	Paraolio Ø 20x42/43x8/9	53502	753.116.00	1	Oil seal Ø 20x42/43x8/9
53503	753.117.00	1	Paraolio Ø 17x28x5.5	53503	753.117.00	1	Oil seal Ø 17x28x5.5
53504	753.118.00	1	Paraolio Ø 22x32x6	53504	753.118.00	1	Oil seal Ø 22x32x6
53506	753.136.00	2	Paraolio Ø 34x39x4	53506	753.136.00	2	Oil seal Ø 34x39x4
--	740.147.00	1	Gruppo variatore con frizione	--	740.147.00	1	Variable transmission clutch set
--	771.124.00	1	Serie paraoli CY 50	--	771.124.00	1	Oil seal set
--	771.145.00	1	Pistone Ø 40,5 - 1°maggiorazione	--	771.145.00	1	Piston Ø 40,5 - 1°
--	771.145.01	1	Pistone Ø 41 - 2°maggiorazione	--	771.145.01	1	Piston Ø 41 - 2°
--	771.143.00	1	Serie segmenti Ø 40.5 - 1°maggiorazione	--	771.143.00	1	Piston ring set Ø 40.5 - 1°
--	771.143.01	1	Serie segmenti Ø 41 - 2°maggiorazione	--	771.143.01	1	Piston ring set Ø 41 - 2°
--	799.102.00	1	Serie guarnizioni MA 50	--	799.102.00	1	Gasket set
--	142.108.03	1	Motore completo EURO 1 (174.108)	--	142.108.03	1	Engine assy EURO 1 (174.108)

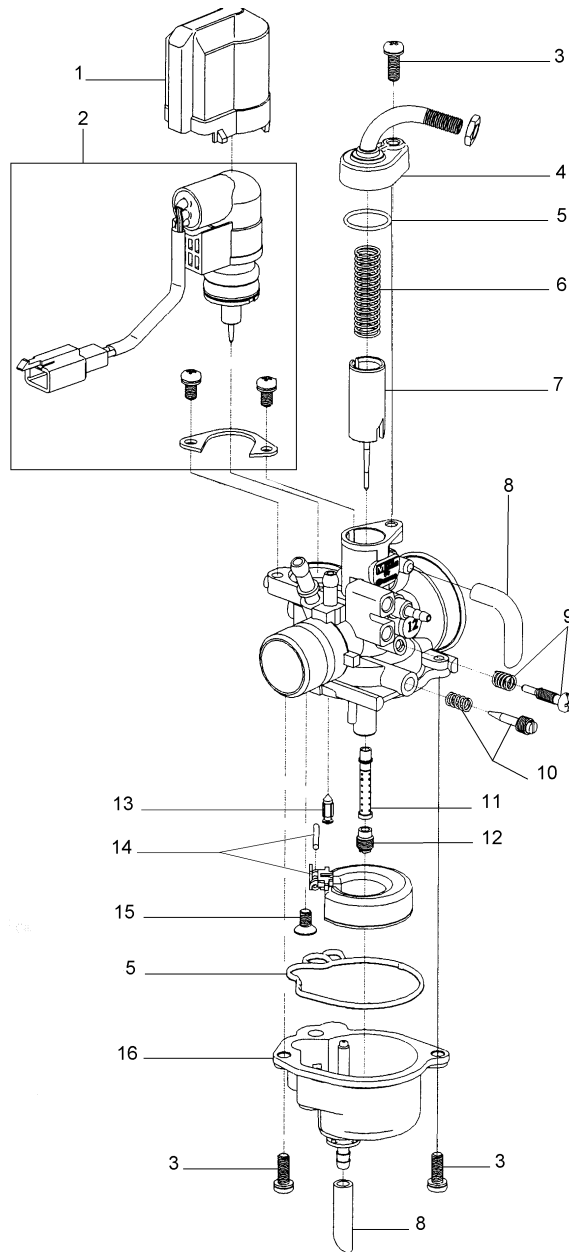

Nr.	Codice	Q.tà	Descrizione
01	623.101.00	1	Cappuccio
02	623.120.00	1	Starter completo
03	623.106.00	3	Vite
04	623.117.00	1	Coperchio completo
05	623.119.00	1	Kit guarnizioni
06	623.098.00	1	Molla valvola gas
07	623.110.00	1	Valvola gas completa
08	623.124.00	1	Kit tubi sfiato - presa aria
09	623.121.00	1	Vite regolazione valvola gas
10	623.122.00	1	Vite regolazione minimo
11	623.113.00	1	Polverizzatore
12	623.143.00	1	Getto max. Ø 60
13	623.114.00	1	Valvola a spillo
14	623.123.00	1	Galleggiante completo
15	623.107.00	1	Vite fissaggio galleggiante
16	623.116.00	1	Vaschetta completa
--	715.090.00	1	Carburatore completo Gurtner PY 12 / R 408

Nr.	Code	Q.tà	Description
01	623.101.00	1	Cap
02	623.120.00	1	Starter, complete
03	623.106.00	3	Screw
04	623.117.00	1	Cover, complete
05	623.119.00	1	Gasket set
06	623.098.00	1	Throttle valve spring
07	623.110.00	1	Throttle valve, complete
08	623.124.00	1	Breather pipe/air intake kit
09	623.121.00	1	Throttle valve adj. screw
10	623.122.00	1	Idling mix adj. screw
11	623.113.00	1	Spray nozzle
12	623.143.00	1	Max jet Ø 60
13	623.114.00	1	Needle valve
14	623.123.00	1	Float assy
15	623.107.00	1	Float clamp screw
16	623.116.00	1	Float chamber
--	715.090.00	1	Carburettor assy Gurtner PY 12 / R 408